

WASTE BIN WH15



260 x 400 x 150 mm

Capacity approx. 15 l

- Waste bin in robust, germ-reducing and easy-care stainless steel (AISI 304).
- All-stainless steel housing; visible surfaces satin finished and brushed.
- Equipped with internal holder for standard garbage bags. Capacity approx. 15 l.
- Mounting: For glueing or with two screws through key holes and one optional anti-theft hole in the back wall.
- Delivery includes fixing material.
- Weight, including single package: 2.8 kg

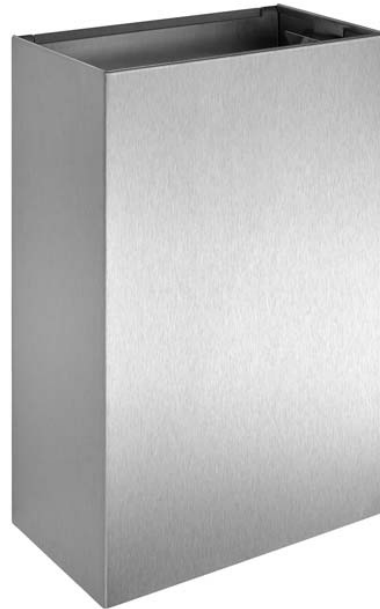

Suggested text for specifications:

Waste bin in stainless steel (AISI 304) for surface mounting. All-stainless steel housing; visible surfaces satin finished and brushed. Equipped with internal holder for standard garbage bags. Capacity approx. 15 l. Delivery includes fixing material.

Dimensions: 260 x 400 x 150 mm

Article No. WH15

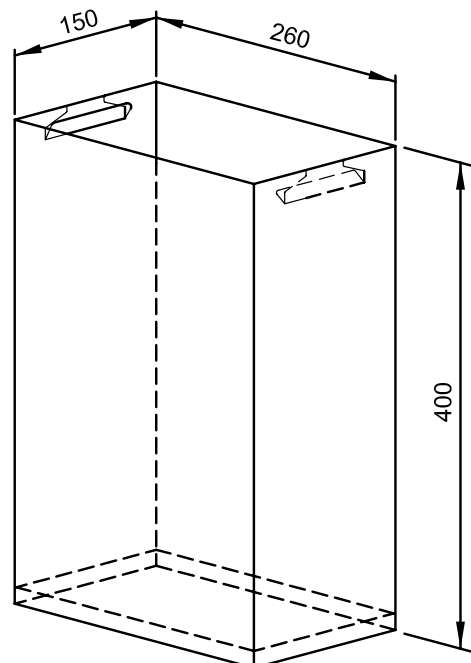

Available surfaces

ID No.

satin finished (standard)

727 347

Ernst Wagner GmbH & Co. KG

Ernst-Abbe-Straße 21 · D-72770 Reutlingen · Tel.: +49712151539-0 · Fax: -20
info@wagner-ewar.de · www.wagner-ewar.de

WAGNER
E W A R